

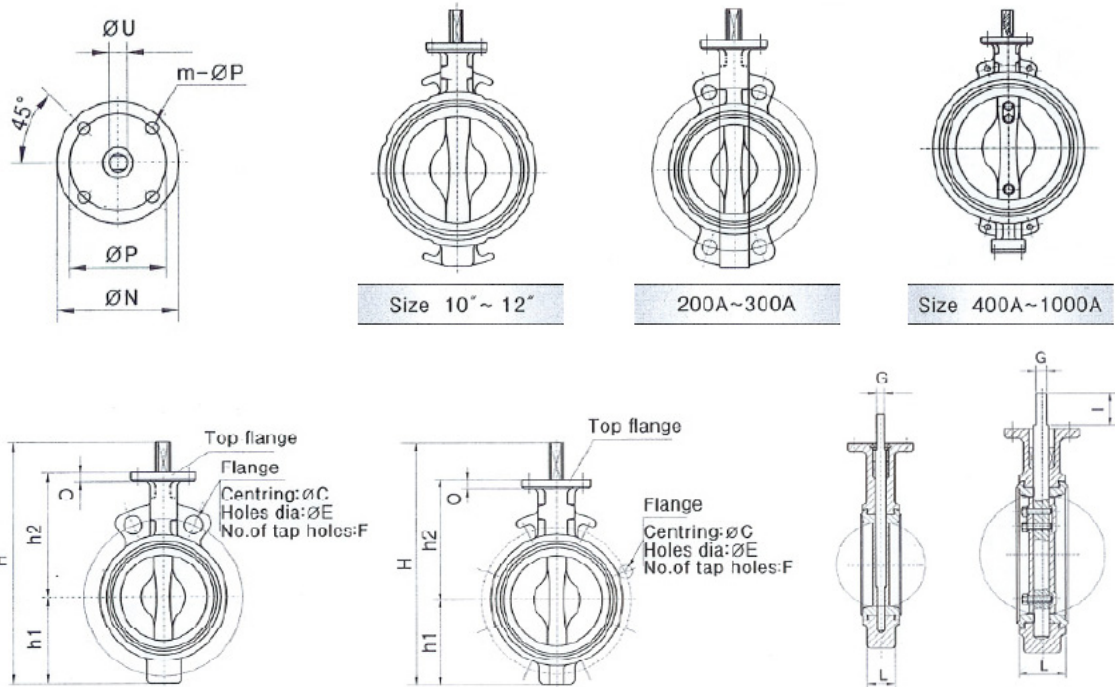

BUTTERFLY VALVE - WAFER BODY



VALVE DIMENSIONS

Size		L	H	h1	h2	Stem		Top flange to ISO 5211					O	WT (kg)
Inch	mm					ØU	G	Type	ØN	ØP	m	ØS		
1½"	40	41	205	58	124	10	8	F07	90	70	4	9	10	3.1
2"	50	43	227	66.5	130.5	14	10	F07	90	70	4	9	11	3.7
2½"	65	46	241	71	140	14	10	F07	90	70	4	9	11	4
3"	80	46	263	83	150	14	10	F07	90	70	4	9	11	4.4
4"	100	52	290	95	163	16	12	F07	90	70	4	9	11	5.9
5"	125	56	319	110	178	19	15	F07	90	70	4	9	12	8.9
6"	150	56	347	124	191	19	15	F07	90	70	4	9	12	9
8"	200	60	433	163	238	22	18	F07	90	70	4	9	13	11
10"	250	68	546	227	285	28	20	F10	125	102	4	12	15	20
12"	300	78	601	252	315	28	20	F10	125	102	4	12	15	31.5

FLANGE DRILLING

Size		L	H	h1	h2	Stem					Top flange to ISO 5211					O	WT (kg)
Inch	mm					ØU	G	I	Y	K	Type	ØN	ØP	m	ØS		
14"	350	78	675	271	324	32	19.5	45	-	-	F10	125	102	4	12	20	43
16"	400	102	817	343	369	35	-	60	5	10	F14	175	140	4	18	23	63.5
18"	450	114	877	366	406	38	-	60	5	10	F14	175	140	4	18	23	99
20"	500	127	1008	421	485	45	-	60	5	10	F16	210	165	4	22	34	114.5
22"	550	140	1050	450	530	45	-	60	5	10	F16	210	165	4	22	34	152
24"	600	154	1180	493	570	50	-	60	5	10	F16	210	165	4	22	34	214.5
26"	650	165	1260	540	570	50	-	120	5	10	F16	210	165	4	22	34	270
28"	700	165	1355	580	574	70	-	120	5	10	F25	300	254	8	18	35	377
30"	750	180	1445	656	615	70	-	120	5	10	F25	300	254	8	18	35	460
32"	800	180	1495	630	669	80	-	140	5.5	14	F25	300	254	8	18	35	542
36"	900	180	1625	690	671	80	-	140	5.5	14	F30	350	298	8	22	38	699
38"	950	200	1650	710	800	90	-	140	5.5	14	F30	350	298	8	22	38	840
40"	1000	200	1802	790	842	90	-	140	5.5	14	F30	350	298	8	22	40	977
48"	1200	276	2130	910	1070	120	-	150	7	22	F30	415	356	8	33	40	1680